

# DEVINE LIBERTY SWING

Warranty

Swing Drawings

Components List

Swing Installation Instruction Procedure

Special Soft Fall Instructions

Minimum Soft Fall and Fencing Plans

Maintenance Program

Standards Compliance Certificate

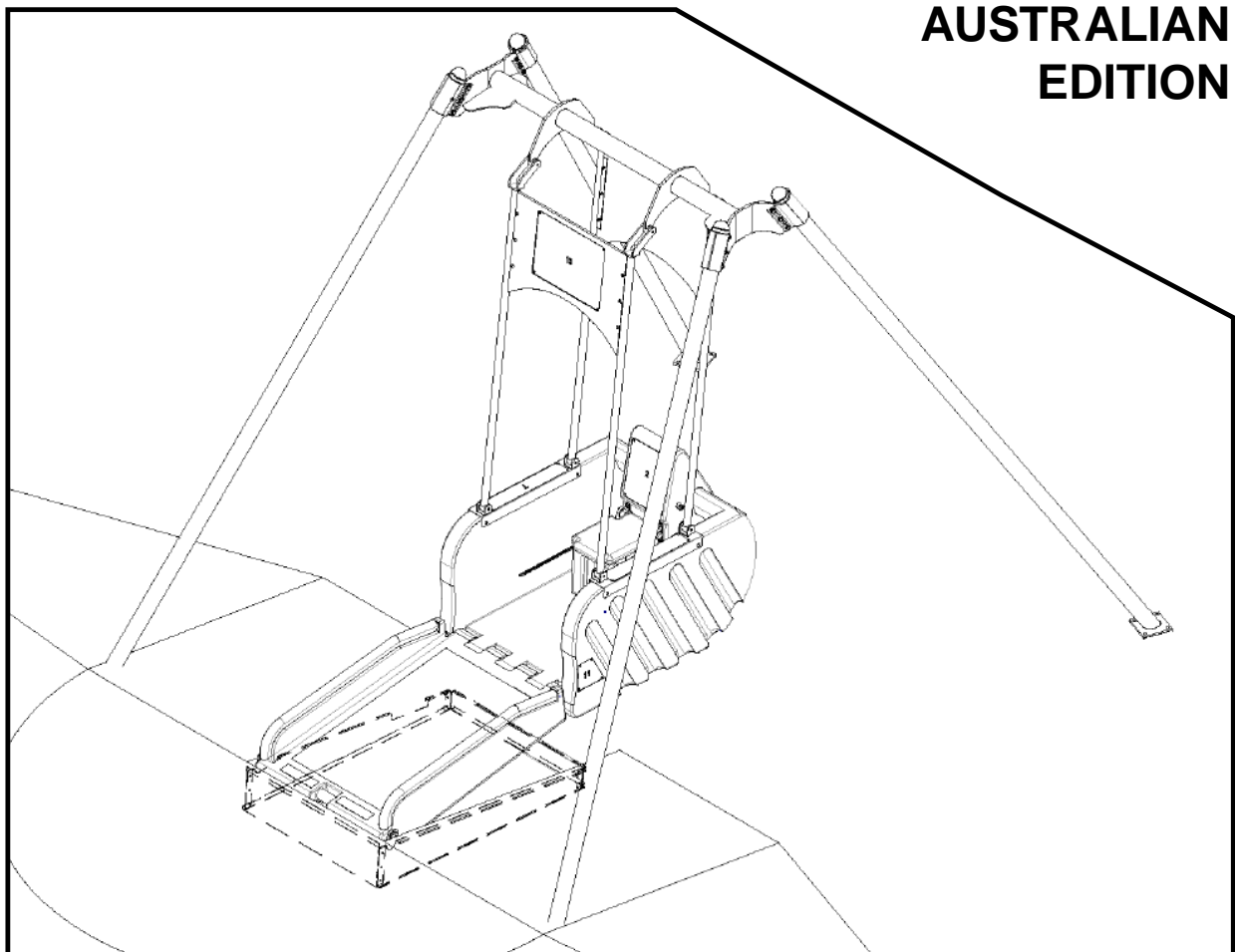

**AUSTRALIAN  
EDITION**

**JENWAY INDUSTRIES PTY LTD**

44 Anderson Rd

Mortdale 2223

NSW Australia

Ph: (02) 9580 6981

Fax: (02) 9580 8398

Email: [w.devine@bigpond.com](mailto:w.devine@bigpond.com)

**JENWAY INDUSTRIES PTY LTD**

44 Anderson Rd

Mortdale 2223

NSW Australia

Ph: (02) 9580 6981

Fax: (02) 9580 8398

ACN: 001 429125

Email: w.devine@bigpond.com

**“DEVINE LIBERTY SWING” WARRANTY**

Your “Devine Liberty Swing” has been manufactured to a high standard of quality control and we therefore extend to you, the original purchaser, a *five* year warranty from the date of purchase against faulty parts or workmanship provided the “Devine Liberty Swing” has not been misused or mishandled. During the warranty period, we undertake to rectify any “fault” or “failure”. Our warranty is subject to your compliance with the following conditions in regard to which our ruling shall be final and conclusive.

**Conditions of Warranty**

1. The warranty extends only to “faults” and “failures” in the “Devine Liberty Swing” occurring during normal use of the “Devine Liberty Swing”, and does not extend to defects caused by misuse, excessively harsh treatment or other mistreatment of the “Devine Liberty Swing”, whether deliberate or accidental.
2. The benefits given to the Purchaser by this warranty are in addition to all the other rights and remedies which the Purchaser has in law.
3. The invoice is the ultimate reference and should be kept as the proof of purchase.
4. A “fault” is a pre-existing condition which results in a piece of equipment not performing as per manufacturer’s specification.
5. A “failure” is a spontaneous occurrence which causes a piece of equipment to cease operating in the way it originally did.
6. Costs of installation of replacement parts shall be at the cost of the Purchaser and repairs to equipment for problems that prove to be non-warranty will be charged at our standard rates and paid for by the Purchaser.

## DEVINE LIBERTY SWING COMPONENTS LIST

(18) On/Off Device	1 included:
(6) Torsion Rod	1
(4) Torsion Bracket	1
(6a) 32mm Gal Tube	1
(8a) Locking Scutch Plate	1
(7) On/Off Device Support Bracket	1
(17) Capsule	1 included:
(9) Seat Belt	1 located in compartment in rear of capsule
(8) On/Off Device Lock	1 located at side of capsule
(3) Wheel Locks	2 located either side of rear of capsule
(20) Internal Seat	1
(15) Seat Belt Anchor Points	2
(16) Top Swing Cross Bar	1
(19) Capsule Support Arms	4
(10) Post Legs	4 T-Nuts, Screws, Female/Male clamps attached
(10a) Post Leg Extension	6
(11) Devine Liberty Swing Signage	2
Spacer Panels	
(14) Sign on post (How to start/finish ride)	1
M.L.A Key	2 supplied
Loctite	1
Never Seize	1

One Sign - Restricted area to be attached to entry gate.

### **Fencing and Soft Fall Not Included**

**The Devine Liberty Swing meets the following Standards:**

- AS1924 Part 1      General Requirements**
- AS1924 Part 2      Design and Construction Safety Aspects**
- AS 2555              Guide to Siting, Installation, Inspection and Operation**
- AS/NZS 4422: 1996 and AS/NZS 4486 Part 1-1997**

### **SPECIAL NOTE**

**Whilst the Devine Liberty Swing meets the required Standards, it “must” be fenced (minimum height 1200mm) with an access gate that is self-closing and fitted with a child-proof locking mechanism, and a sign placed on the gate that reads: (supplied)**

**RESTRICTED AREA, USERS AND CARERS ONLY AS REQUIRED IN THIS AREA**

## STEPS FOR SWING INSTALLATION

(Note: All dimensions in mm)

<b>STEP 1</b>	Place top swing cross bar (16) on ground upside down, so legs can be secured facing upwards.
<b>STEP 2</b>	<p><b>Connection of post legs to top swing cross bar</b></p> <p>Remove post button screws, t-nuts and male clamp from the post legs (10).</p> <p>Place post legs to align with top swing cross bar bolt holes. Attach male clamp to female clamp. Secure in place with post button screws and t - nuts (all fasteners are supplied). Apply <i>Loctite</i> provided to the screws, then insert into holes and tighten screws.</p>

Item No.	Title
16	TOP SWING CROSS BAR
10	POST LEG
10b	3/8 T - NUT
10c	FEMALE CLAMP
10d	MALE CLAMP
10e	3/8 x 1.25" SS POST BUTTON SCREW

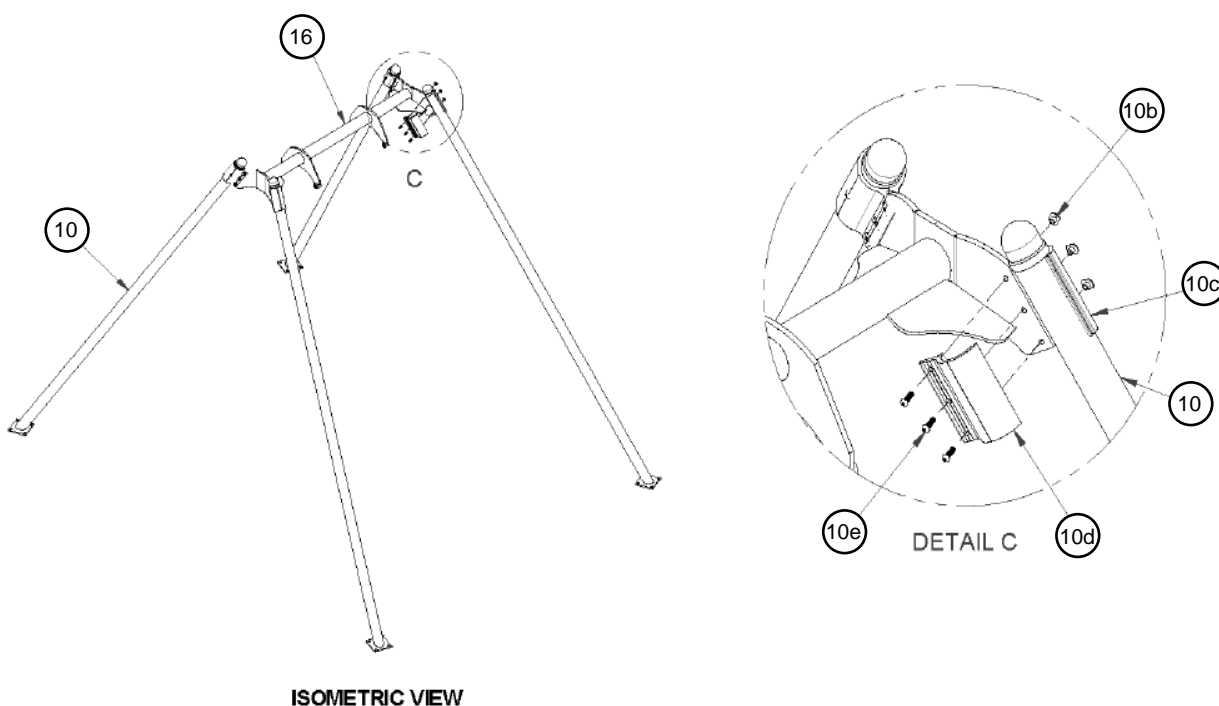

<p><b>STEP 3</b></p>	<p><b>Position of swing frame</b></p> <p>Invert swing frame so legs are in approximate position where holes are to be excavated.</p> <p>Locate swing to desired position:</p> <p><b>Australia:</b> ideal positioning of the swing is to face south, south east or slightly south west.</p> <p><b>Overseas:</b> ideal positioning would be in a direction that in mid summer, the user's back is facing the sun.</p> <p>Mark final position of holes to be dug.</p>
<p><b>STEP 4</b></p>	<p><b>Excavation of holes</b></p> <p>Move swing frame to side of working area</p> <p>Dig holes to depth as per footing instructions drawing</p> <p>Ensure all excavated holes are levelled</p>
<p><b>STEP 5</b></p>	<p>Place all post legs extension (10a) into the holes</p> <p>Move swing frame over extension plates</p> <p>Attach swing frame to extension plate with bolts provided</p>

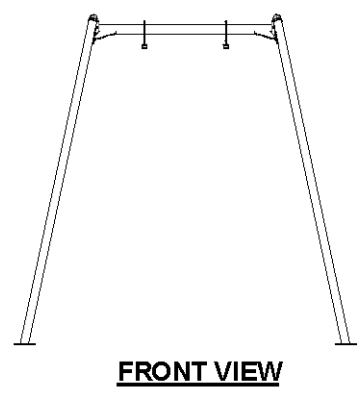
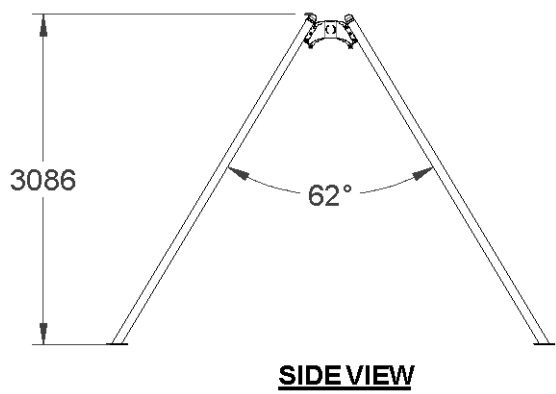
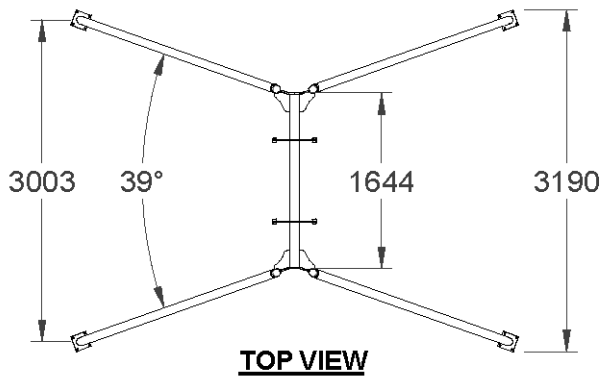

**STEP 6**

**Attachment of capsule**

Attach four capsule support arms (19) to swing head cross bar (16) as per position indicated in swing diagram, with bolts supplied.

*Loctite* all bolts - tighten bolts.

Attach capsule (17) to capsule arms (19) ensuring that user direction is facing that suggested in STEP 3, with bolts supplied.

Attach two arched swing signage spacer panels (11) to capsule arms (19), with bolts supplied.

**STEP 7**

**Concrete footing holes**

Concrete four swing frame legs (10) with completed swing frame unit inserted into a level position. Leave for concrete to cure.

(Standard pre-mix 457 Dia. x 914 Deep)

Item No.	Title
19/ 2 OFF	RH CAPSULE SUPPORT POLE
19/ 2 OFF	LH CAPSULE SUPPORT POLE
11/ 2 OFF	SWING SIGNAGE SPACER PANEL
17	SWING CAPSULE
10a/ 6 OFF	POST LEG EXTENSION

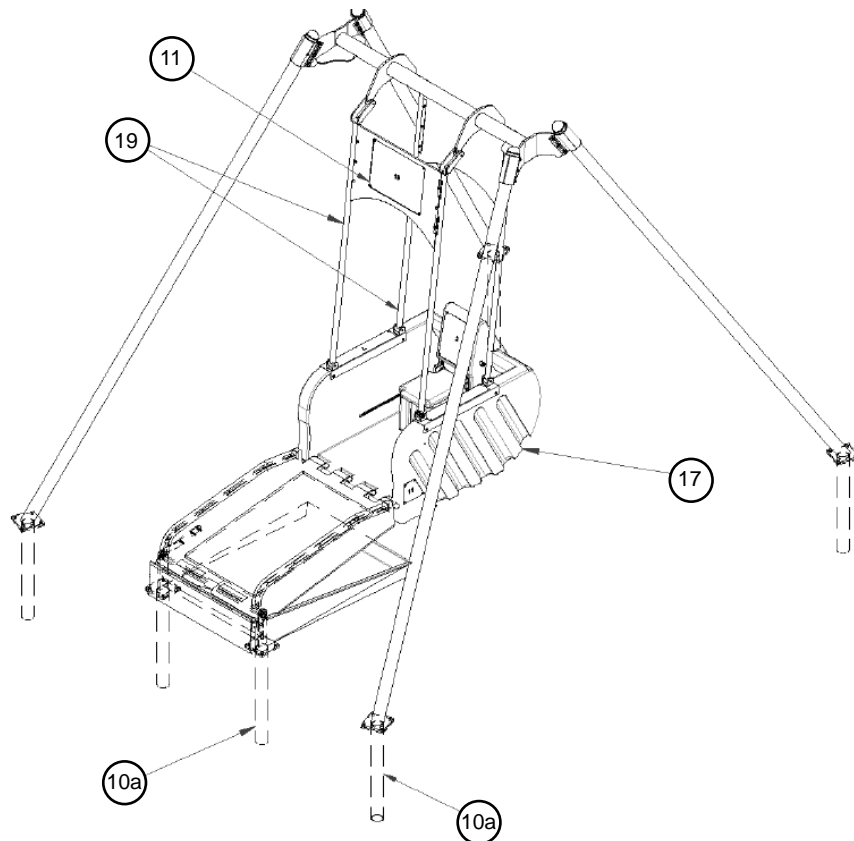

**ISOMETRIC VIEW**

**STEP 8**

**Positioning of on/off device and on/off device legs**

Remove gal tube (6a) and torsion rod (6) from on/off device leg item (7)

Item No.	Title
7	ON/OFF DEVICE SUPPORT BRACKET
6a	TORSION BAR GALVANISED TUBE
6	TORSION ROD

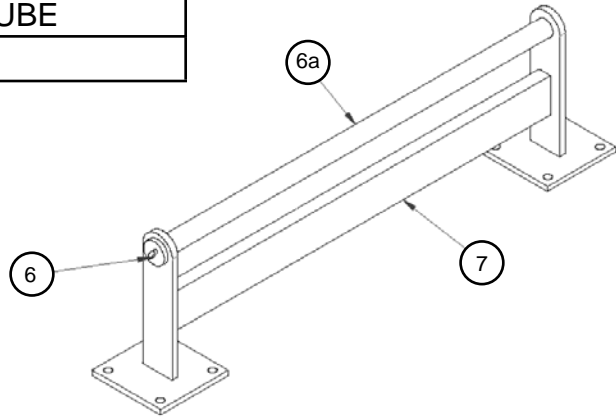

**ISOMETRIC VIEW**

Remove torsion bracket (4) from on/off device (18)

Attach on/off device support bracket (7) to on/off device (18) with gal tube (6a)

Replace torsion bar bracket (4) - **NOT torsion rod (6) at this time**

Item No.	Title
18	ON/OFF DEVICE
7	ON/OFF DEVICE SUPPORT BRACKET
4	TORSION BRACKET
3 OFF	3/8 x 1.25" SS POST BUTTON SCREW

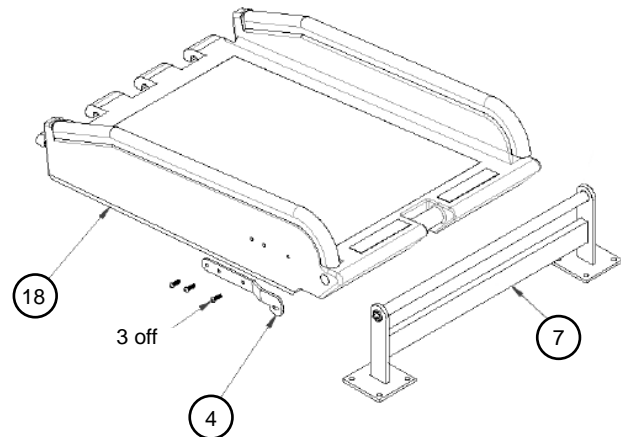

**EXPLODED ISOMETRIC VIEW**

**STEP 8  
CONTINUED**

Prop capsule (17) forward in a parallel position 250mm from vertical position (see attached drawing). This will ensure the capsule will release with clearance from the on/off device

Position the on/off device (18) on the capsule (17) for marking on/off device support bracket (7) hole position

Mark position for on/off device support bracket (7) holes

**It is imperative that the on/off device support bracket (7) when concreted is level and plum, failure to do this could adversely affect the operation of the on/off device.**

Move on/off device to side to enable holes to be excavated

Excavate holes as per footings drawings

Attach post leg extension (10a)

Replace the on/off device to the capsule

Concrete on/off device legs into position

**Ensure the legs are plum and level as this has a direct bearing on the function of the torsion bar.**

Leave in position until concrete is fully cured before fitting torsion rod (6) and locking scutch plate (8a)

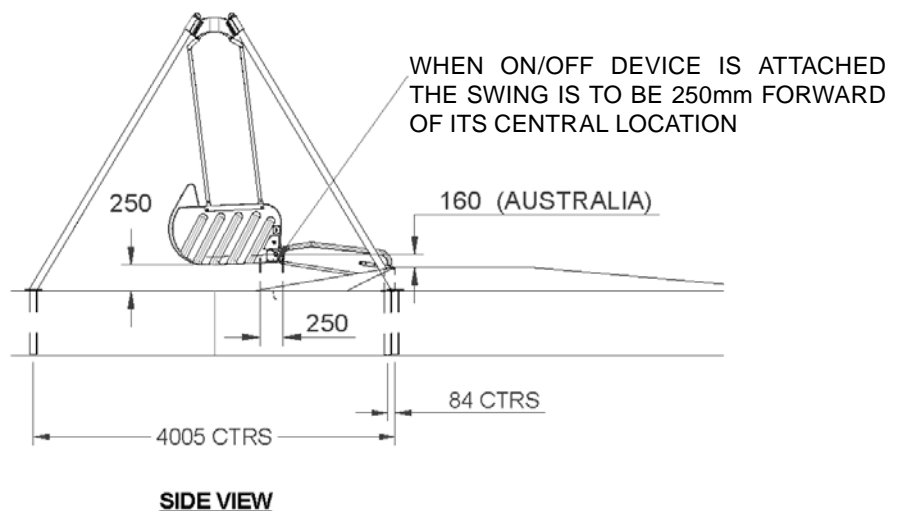
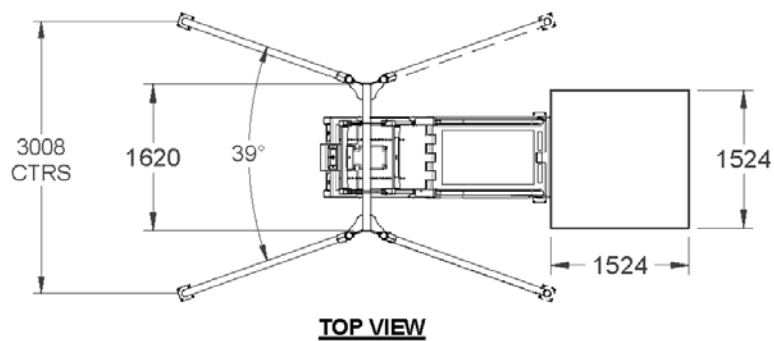

**STEP 9**

**Fitting sign: How to start/finish ride**

Preferred location is close proximity to the swing and on the side of the key lock. Mark, dig hole and concrete.

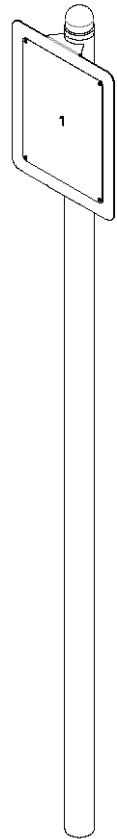

**STEP 10**

**Fitting torsion rod**

Remove torsion bracket (4) from the on/off device (18)  
 Insert torsion rod (6) into prior installed gal tube (6a) to key way at opposite side of on/off device support bracket (7)  
 Lift on/off device (18) off capsule (17) to approximately 60°  
 Fit torsion bracket (4) over end of torsion rod (6) and bolt to on/off device (18)  
 Lower on/off device and attach to capsule (17)

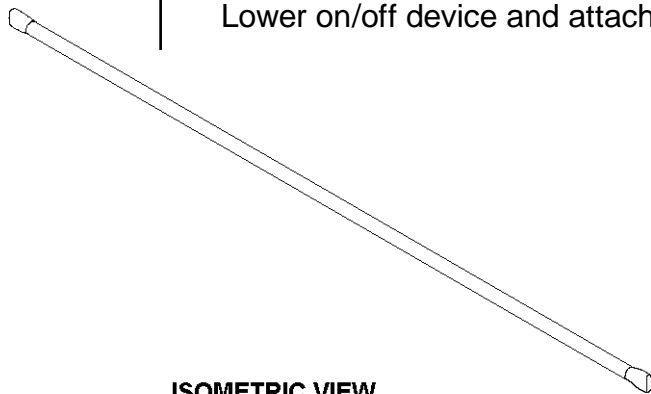

ISOMETRIC VIEW

ISOMETRIC VIEW

**STEP 11**

**Fitting scutch plate to on/off device (locking device)**

Mark locations on on/off device (18) where lock rod from lock (8) protrudes through from capsule (17)  
 Drill a hole and widen so lock rod engages to on/off device and can be operated by key supplied  
 Mark holes as per scutch plate (8a) and fix in position with rivets supplied; make sure lock (8) operates smoothly

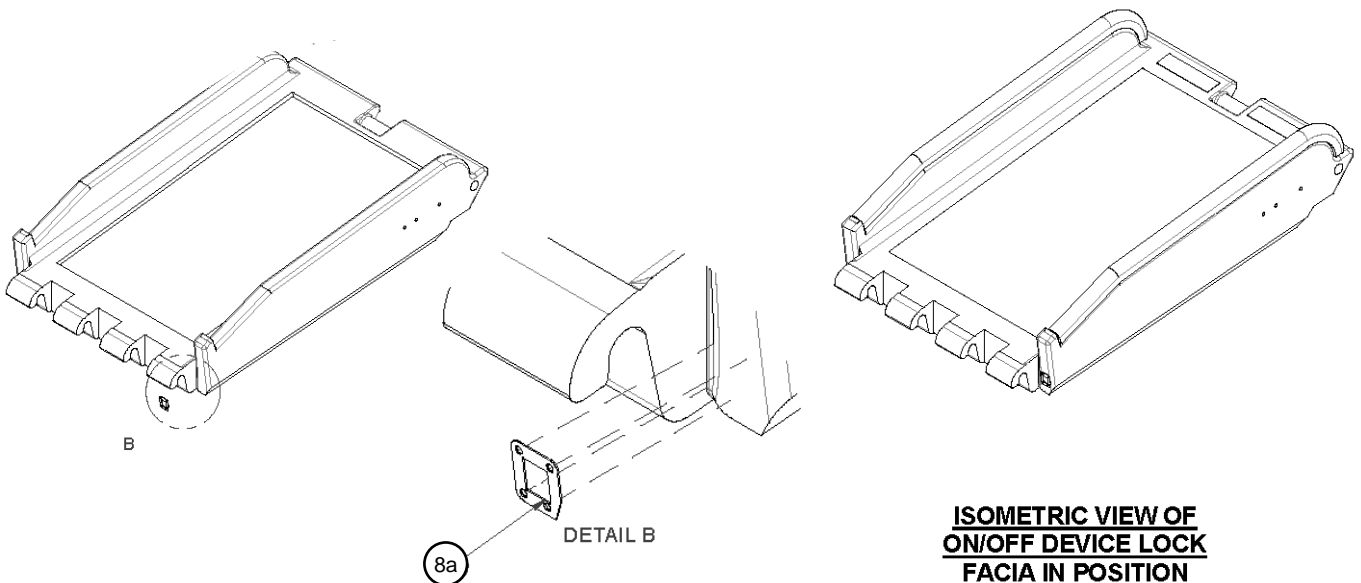

ISOMETRIC VIEW OF ON/OFF DEVICE LOCK FACIA IN POSITION

**STEP 12**

**Signage**

Fit sign to gate that reads: (supplied)

RESTRICTED AREA, USERS AND CARERS ONLY AS  
REQUIRED IN THIS AREA.

TO BE PLACED  
ON THE GATE

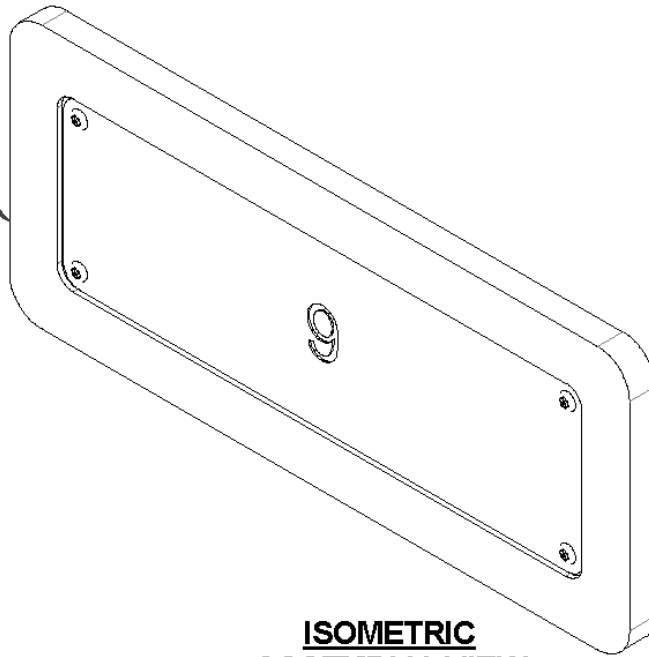

**ISOMETRIC  
ASSEMBLY VIEW**

## SPECIAL SOFT FALL INSTRUCTIONS

These instructions relate to the installation of rubber to on/off device from access and formation of sunken well into which the on/off device will be lowered.

### STEP 13

#### Soft fall installation - on/off device

Soft fall must comply with current standards with a recommended fall height of 1.8m and fall zone dimensions of:

Width 2.9m between support posts

Length 4.5m each side of crossbar (9.0m total)

The access way should be formed in such a way that there is a reasonable level area at the bottom of the on/off device - to allow the wheelchair to be turned around to reverse up the on/off device to the swing

Approximately 1524mm by 1524mm

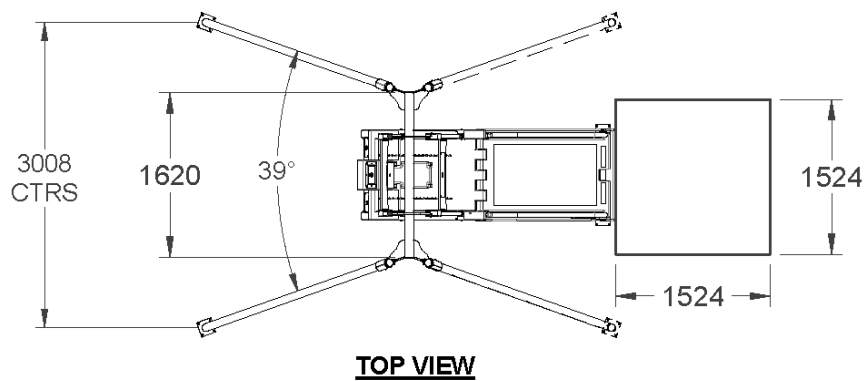

WHEN ON/OFF DEVICE IS ATTACHED  
THE SWING IS TO BE 250mm FORWARD  
OF ITS CENTRAL LOCATION

To meet standards the distance between the seat and ground must be greater than 250mm over the complete swings circumference.

**STEP 13**  
**CONTINUED**

When laying the rubber access way, the on/off device should be in the locked position to get a good match with the on/off device level - if the on/off device is in the down position, the level will not be right due to the pivot point of the on/off device.

On/off device access is to be formed to allow a transition onto the detachable on/off device

USA: All to comply with (ADAAG) and specifications F1292, 4.5.1 and 4.5.2 and specification F1951

Under side of on/off device rubber to be formed to allow the on/off device (18) to sit at a rest in a well-type setting as shown on drawings with hooks of on/off device (18) level with top of soft fall.

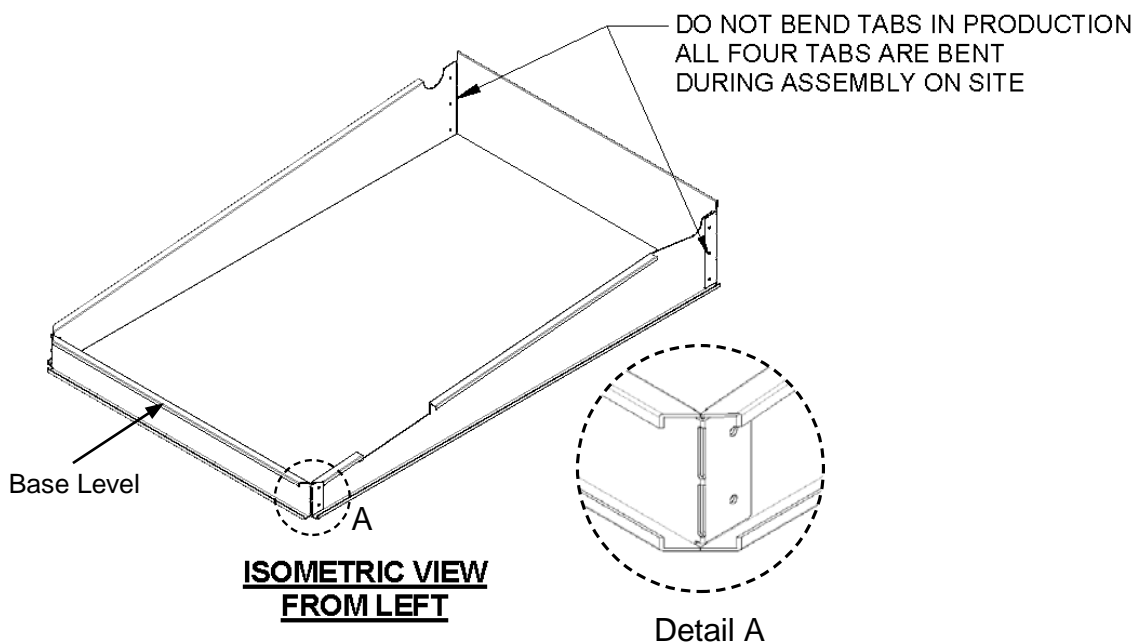

## MAINTENANCE PROGRAM

To ensure that the Devine Liberty Swing is properly maintained, please ensure that the inspection checklist is adhered to as stipulated by the table below.

### INSPECTION CHECKLIST

- Capsule** To be inspected for cleanliness, graphite to be removed straight away.
- Nuts/Bolts** To be inspected that all are tight.
- Locks** To be checked for good working order.
- Seatbelt** To be checked in good condition and have no cuts or fraying.
- On/Off Device** Check that it is in correct position and easy to move, check condition.
- Site** Check site is clear of all dangerous and unsuitable objects, check site for hygiene problems.
- Joints** Check all welds so that they have no corrosion or cracks.

Day	1	2	3	4	5	6	7
<b>First Week</b>	X	X	X	X	X	X	X
<b>Second Week</b>	X		X		X		X
<b>Third Week</b>				X			
<b>Fourth Week</b>	X	X	X	X	X	X	X

It is then recommended that the swing be inspected on a regular basis and be incorporated in to the council's maintenance program.



**CONSULTING COORDINATION Pty Ltd**

*ENGINEERS & PLANNERS*

PO Box 823 Beenleigh 4207  
 Queensland AUSTRALIA  
 62 Luscombe Cres Wolffdene  
 Telephone: + 61 7 5546 4176  
 Facsimile: + 61 7 5546 4460  
 Email: clived@mpx.com.au

**STANDARDS COMPLIANCE CERTIFICATE – PLAYGROUND EQUIPMENT**  
**DEVINE LIBERTY SWING**

**MANUFACTURER:** JENWAY INDUSTRIES  
 44 ANDERSON ROAD  
 MORTDALE NSW 2223  
 AUSTRALIA

**COMPONENT RANGE:** DEVINE LIBERTY SWING

**FREE HEIGHT OF FALL:** 1.8 METRES

**FALL ZONE DIMENSIONS:** WIDTH - 2.9m BETWEEN SUPPORT POSTS  
 LENGTH – 3.8m EACH SIDE OF CROSSBAR  
 (7.6m TOTAL)

We, Consulting Coordination Pty Ltd of 62 Luscombe Crescent, Wolffdene Queensland 4207 hereby certify that we have assessed the LIBERTY SWING equipment Free Height of Fall and Fall Zone Dimensions as specified above for compliance with current Australian Standards. Based on our assessment, we are satisfied that the LIBERTY SWING equipment Free Height of Fall and Fall Zone Dimensions specified above satisfy the requirements of AS1924 Part 1-1981, AS1924 Part 2-1981, AS/NZS4422:1996 and AS/NZS4486 Part 1-1997 when the LIBERTY SWING is installed in accordance with the specifications of the manufacturer. This certificate supercedes the previous certificate dated 13<sup>th</sup> April 2004.

Signature.....

Date... 27th July 2004 .....

CLIVE DODD B Eng (Civil), MURP, MIE Aust, CP Eng, RPEQ 1985, LGE (Qld) 1036

### Minimum softfall (dotted line) and suggested fencing layout options

MINIMUM SOFT FALL  
AREA REQUIRED

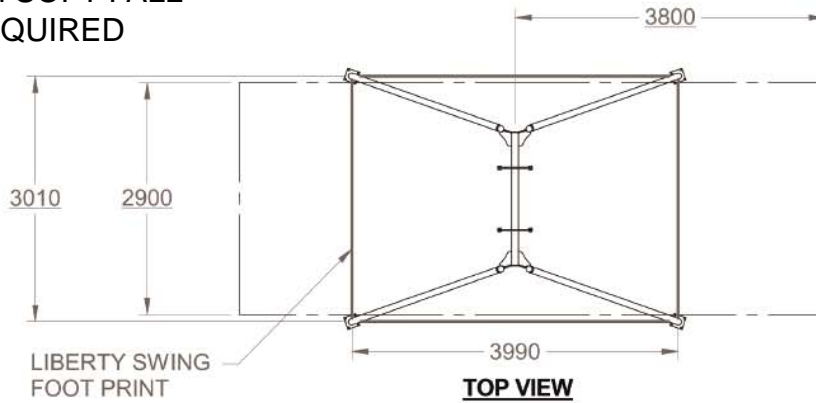

SUGGESTED  
FENCING  
OPTION 1

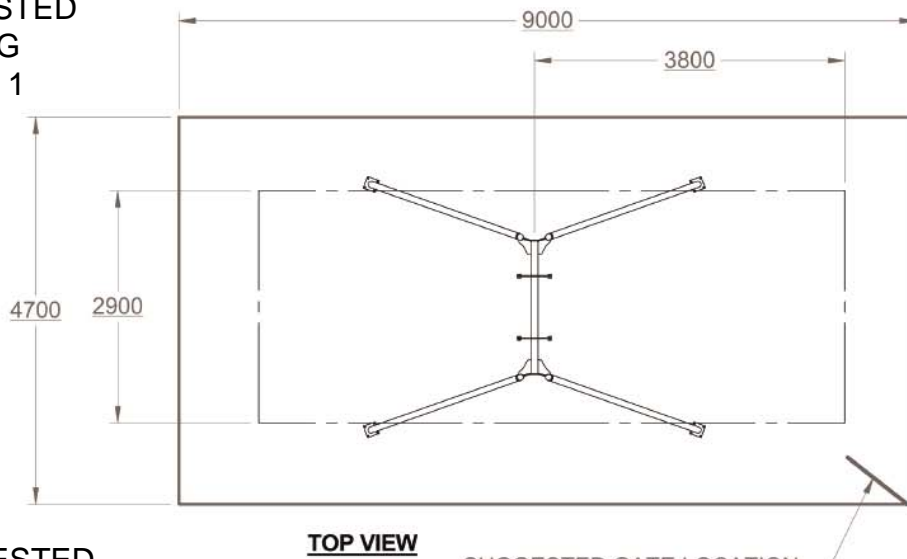

SUGGESTED  
FENCING  
OPTION 2

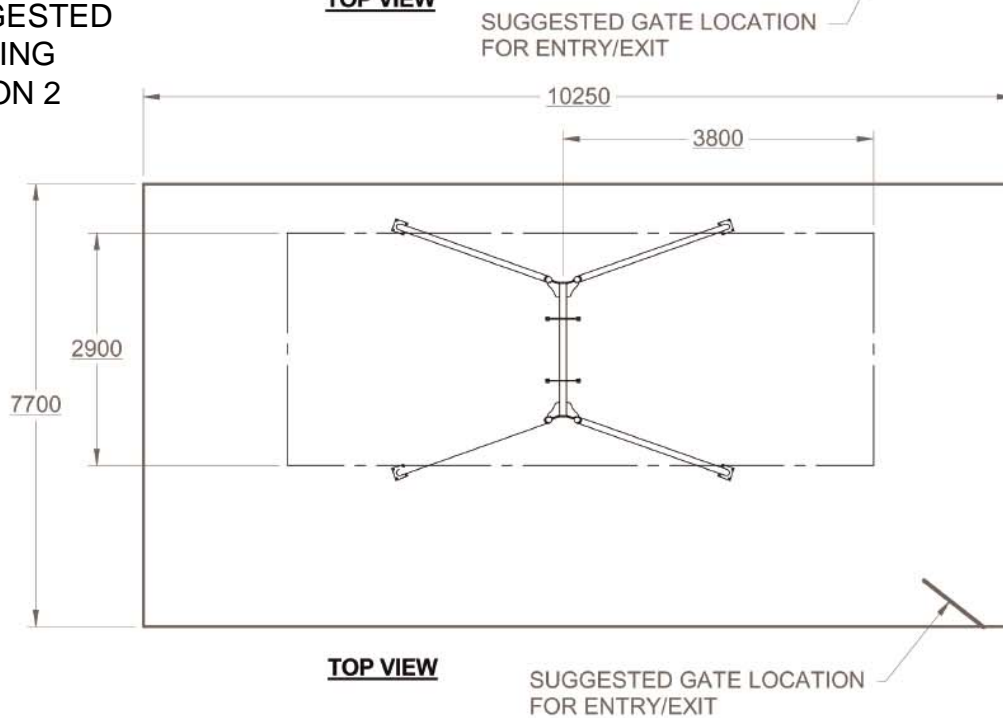

**(Liberty Swing must be fenced)**

**Warwick Donnelly Pty Ltd**

**Consulting Structural and Civil Engineers**

10 Perry Road Arcadia NSW 2159  
Telephone: (02) 9656 1457  
Facsimile: (02) 9656 1458  
Email: wdpl@inet.net.au  
ABN 32 002 074 286

The Manager  
Jenway Industries Pty Ltd  
44 Anderson Road  
MORTDALE NSW 2223

11 April 2006  
Ref: L0613A

Attention: Mr Wayne Devine

Dear Sir

**RE: STRUCTURAL ASSESSMENT OF THE LIBERTY SWING FOOTINGS**

Following our recent discussions, we have completed a structural assessment of the Liberty Swing footings. Please find attached an A4 drawing, number 0613-S01, detailing standard footing requirements and including the design loads for non standard foundation situations.

Liberty Swings to be supported to slabs should be secured at each support leg with 4/M12160 Chemset anchors or equivalent, either galvanised or stainless steel. Anchors should be embedded a minimum of 110mm into the slab with a minimum slab edge distance of 165mm. Slabs should have a minimum concrete strength of 25 MPa, and be designed to accept the working design loads detailed on the above mentioned drawing.

We trust that this assessment will be of assistance.

Yours faithfully

Warwick Donnelly  
B.E.,M.Eng.Sci.,M.I.E.Aust.  
Director

# LIBERTY SWING FOOTING OPTIONS

FOUNDATION MATERIAL TYPE	RATED MATERIAL BEARING CAPACITY (KN/M <sup>2</sup> )	D FOOTING DIAMETER (OR SQUARE)	E EMBEDMENT DEPTH	X MAXIMUM NON-STRUCTURAL OVERBURDEN
SAND CLEAN NATURAL AND UNDISTURBED	75 - 100	350	650	100
NATURAL CLAY MEDIUM TO STIFF	100 - 150	350	650	150
NATURAL CLAY VERY STIFF	200 - 250	300	600	200
BEDROCK SHALE, SANDSTONE OR SIMILAR.	450 +	300	500	250
INERT ENGINEERED FILL (98% COMPACTION)	150	350	650	100
UNCONTROLLED FILL, PROBLEM SITES AND EXCESS OVERBURDEN	-	REFER TO A STRUCTURAL OR GEOTECHNICAL ENGINEER FOR SITE SPECIFIC DESIGN DETAILS.		

ALL DIMENSIONS IN MM

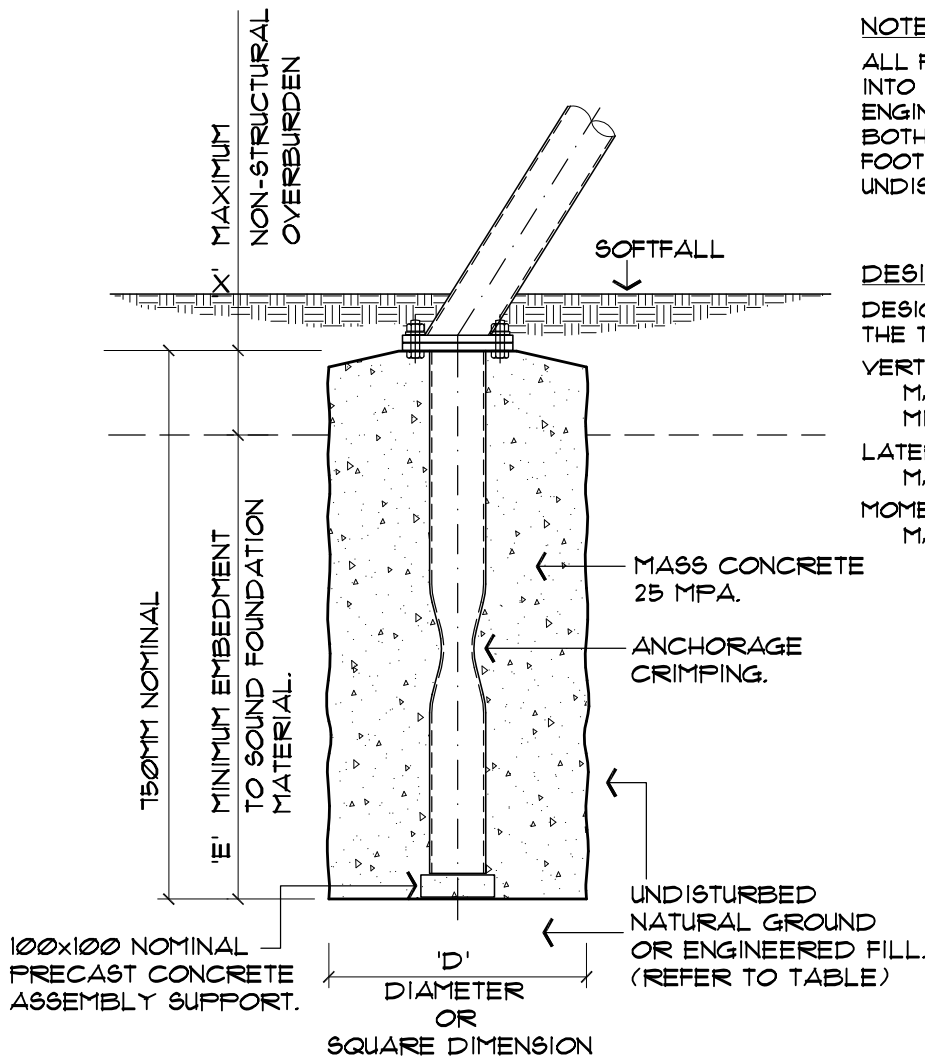

**NOTES:**

ALL FOOTINGS SHALL BE CAST INSITU INTO SOUND NATURAL GROUND OR ENGINEERED FILL. BOTH THE BASE AND SIDES OF THE FOOTING SHALL BE CAST TO UNDISTURBED MATERIAL.

**DESIGN LOADINGS:**

DESIGN WORKING LOADS APPLIED AT THE TOP OF EACH FRAME LEG FOOTING.

**VERTICAL LOAD:**

MAXIMUM — 3.5 KN  
MINIMUM — -0.5 KN (IE UP)

**LATERAL LOAD:**

MAXIMUM — 2.5 KN

**MOMENT:**

MAXIMUM — 0.5 KN M  
+ LATERAL RESTRAINT ECCENTRICITY

JENWAY INDUSTRIES PTY LTD  
LIBERTY SWING

WARWICK DONNELLY PTY LTD  
CONSULTING STRUCTURAL & CIVIL ENGINEERS  
10 PERRY ROAD ARCADIA 2159  
PHONE: 9656 1457  
FAX: 9656 1458  
ABN 32 002 074 286

DRAWING SCALE: 1:10, UNO  
PLOT SCALE: 1:10  
DATE: APRIL 2006

DRAWING:  
FOOTING OPTIONS

PROJECT NUMBER: 0613  
DRAWING: S01